



TOWN OF PERINTON

1350 TURK HILL ROAD ■ FAIRPORT, NEW YORK 14450-8796
(585) 223-0770 ■ Fax: (585) 223-3629 ■ www.perinton.org

DECK RESOURCES & CONSTRUCTION GUIDE

Based on the 2025 Residential Code of New York State (2025 RCNYS) Practical, Illustrated Guide for Building a Single-Level Deck.

This guide is written for a typical residential deck and summarizes the prescriptive requirements in the 2025 RCNYS (Section R507 and related)

Please reach out to the Building & Codes Department with questions (585) 223-0770 or email building@perinton.org

Table of Contents

- 1) Planning & Permits
 - 2) Design & Loads (what code requires)
 - 3) Footings & Posts
 - 4) Ledger attachment & Flashing (attached decks)
 - 5) Joist & Beam Span Tables (how to size)
 - 6) Lateral Connection
 - 7) Guards (railings), Stairs & Handrails
 - 8) Typical construction sequence
 - 9) Inspection checklist
 - 10) Deck Plan Example
-

1) Planning & permits

- **Permit:** Prior to commencement of work, a building permit must be obtained from the Building & Codes Department. Allow at least two weeks for the permit process.
 - **Setbacks & easements:** Decks are subject to the property line setbacks for the zoning district where the property is located. Contact the Building & Codes Dept. to confirm your setbacks.
 - **Utilities:** Call 811 before digging for footings. This is a free service and could prevent serious injury, utility disruption and substantial repair costs due to damaged infrastructure.
 - **Final certificate:** A certificate of compliance must be issued by the town prior to beginning normal use of the deck.
-

2) Design & Loads (what the code requires)

- Metal fasteners and connectors used for all decks shall be galvanized or stainless-steel nails, bolts, lag screws and/or metal connectors. Connectors shall be installed in accordance with the manufacturer's approved instructions. Check with a Building Inspector for alternate approved fasteners.
- Decks must be designed for the live load required in the code, in our area, that's 40 psf (Table R301.2 of the 2025 RCNYS)
- Guard/rail loads: Guards and handrails must resist a minimum of 200lbs of concentrated and uniform loads (Table R301.5 of the 2025 RCNYS).
- If your deck is large, unusual, or supports a hot tub or heavy equipment, an engineer/architect must design the structure and provide stamped drawings.

Why this matters: The live-load value controls joist, beam, and footing sizing & spacing — under sizing any of these is unsafe.

3) Footings & Posts

- **Footings:** Must be sized to carry imposed loads from deck to ground below the frost depth. Typical prescriptive tables provide footing diameter/thickness based on tributary area and soil-bearing capacity.
- **Footing depth:** 42 inches below grade
- **Posts:** Use manufacturer-specified post-base connectors to isolate wood from concrete. Posts must be sized according to tributary area and supported on concrete footing or approved foundation.

Live/Ground Snow Load (psf)	2,000 psf - LOAD BEARING VALE OF SOILS			
	TRIBUTARY AREA (ft2)	Size of a square footing (inches)	Size of a round footing (inches)	Concrete Thickness
40	5	7	8	6
	20	9	9	6
	40	12	14	6
	60	15	17	6
	80	17	19	6
	100	19	21	6
	120	21	23	6
	140	22	25	6
	160	24	27	7

WHAT IS TRIBUTARY AREA: Tributary area for decks is the amount of weight/load, based on square footage of the deck surface, supported by a particular post and footing.

Calculating tributary area is a critical step in deck building, as it determines the size of posts and footings you should use. The tributary area tells you how the deck's maximum load capacity will get distributed. Depending on the design, not all posts and footings will have the same tributary area.

4. Focusing on the length of the beam run (in this case it's 16'), identify the location of the posts under the beam run. Then, identify the halfway point between each of the posts. The measurement between the halfway point on each side of the center post (multiplied by 7) equals the tributary area for Section C. The measurement from the identified center points to each edge of the deck (multiplied by 7) equals the tributary area for Sections B and D.

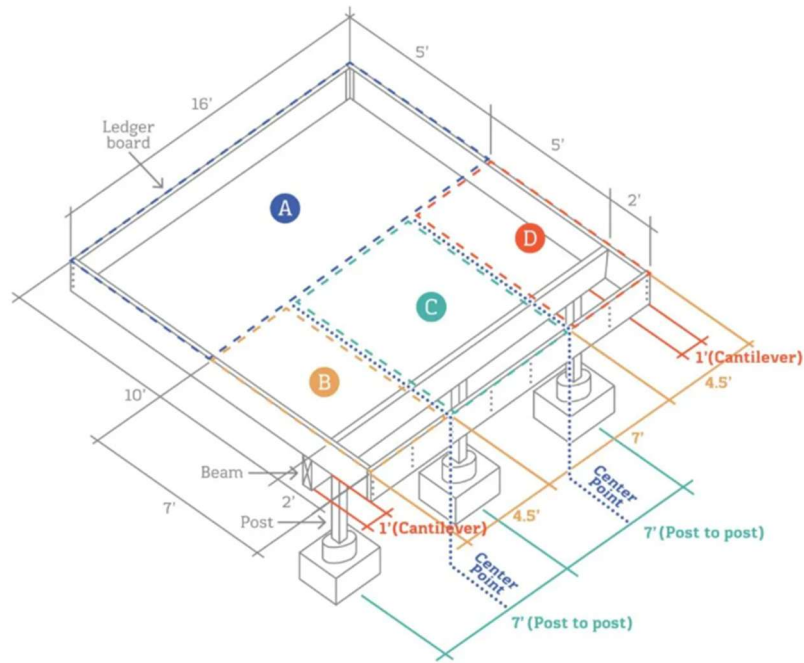

Now you have length and width values for Sections B, C, and D. Multiply the length and width of each to find each section's tributary area:

$$\text{Section B: } 7' \times 4.5' = 31.5 \text{ square feet}$$

$$\text{Section C: } 7' \times 7' = 49 \text{ square feet}$$

$$\text{Section D: } 7' \times 4.5' = 31.5 \text{ square feet}$$

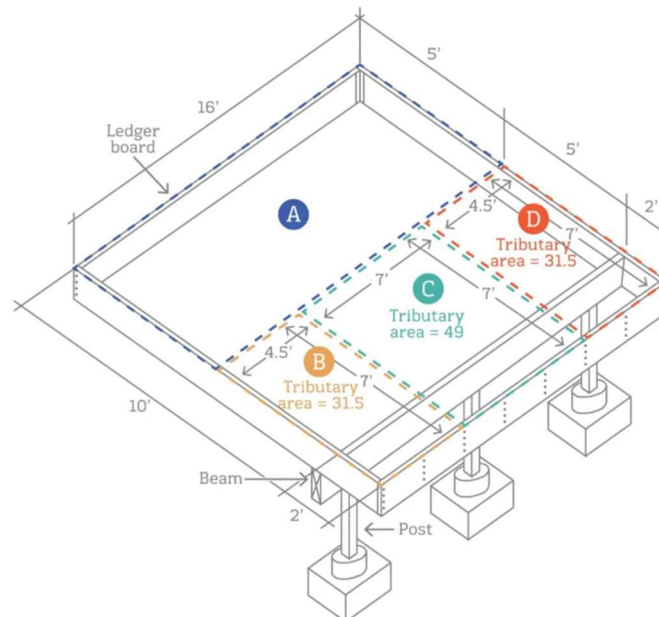
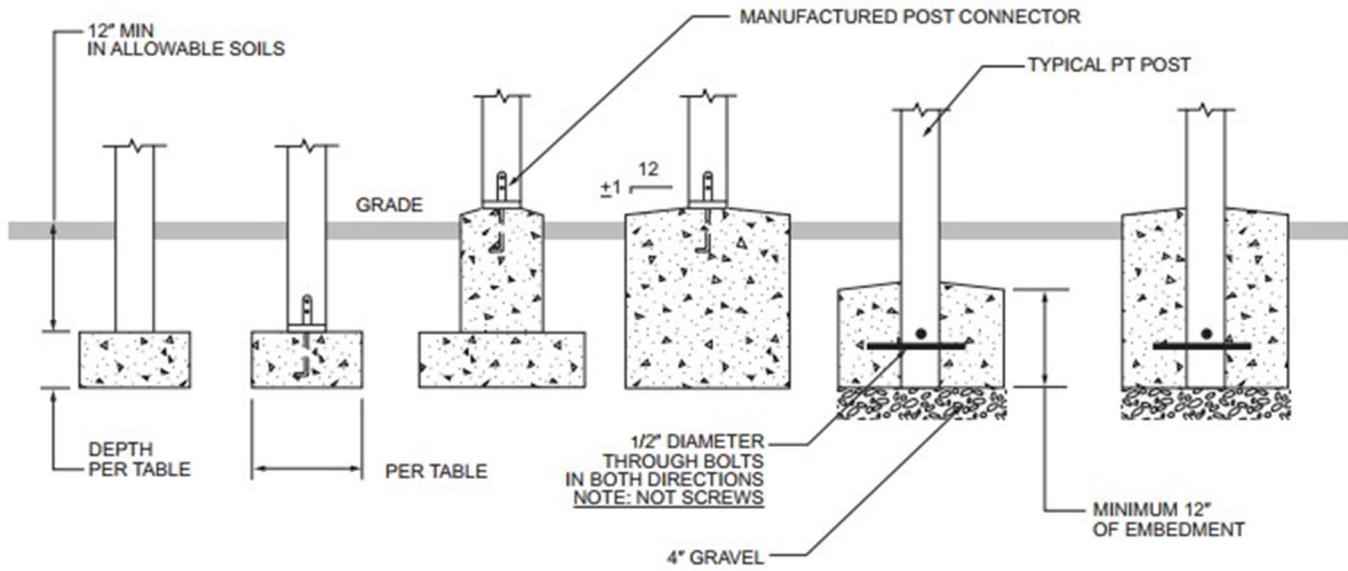

FIGURE R507.3 – DECK POST TO FOOTING CONNECTION



NOTE:
POSTS MUST BE CENTERED ON OR IN FOOTING

4) Ledger attachment & flashing (attached decks)

- Minimum ledger size is 2"x8" (R507.9.1.1 of the 2025 RCNYS)
- The ledger must be fastened to the house band joist/rim joist using the fastener schedule in the code (Table R507.9.1.3(1) of the 2025 RCNYS). Typical options include 1/2" lag screws or through-bolts, spaced per the prescriptive table. Check with a Building Inspector for alternate approved fasteners.
- Ledgers cannot be attached to hollow core block with Tapcon screws or wedge anchors. Follow manufacturer's instructions. Consult an inspector if you have questions.
- Ledgers cannot be attached to a cantilevered floor (R507.9.1.2 of the 2025 RCNYS)
- Where a ledger cannot be attached to the band joist, construct a free-standing deck, or consult a design professional.

TABLE R507.9.1.3(1) – DECK LEDGER CONNECTION TO BAND JOIST

LOAD (psf)	JOIST SPAN (ft)	ON-CENTER SPACING OF FASTENERS (inches)		
		1/2" dia. Lag screw w/1/2" max. sheathing	1/2" dia. bolt w/1/2" max. sheathing	1/2" dia. Lag screw w/1" max. sheathing
40	6	30	36	36
	8	23	36	36
	10	18	34	29
	12	15	29	24
	14	13	24	21
	16	11	21	18
	18	10	19	16

FIGURE R507.9.1.3(1)—PLACEMENT OF LAG SCREWS AND BOLTS IN LEDGERS

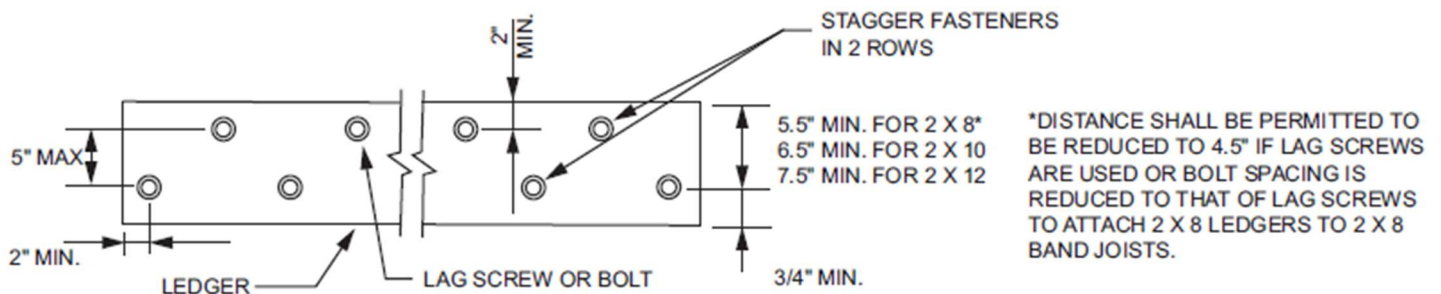

For SI: 1 Inch = 25.4 mm.

FIGURE R507.9.1.3(2)—PLACEMENT OF LAG SCREWS AND BOLTS IN BAND JOISTS

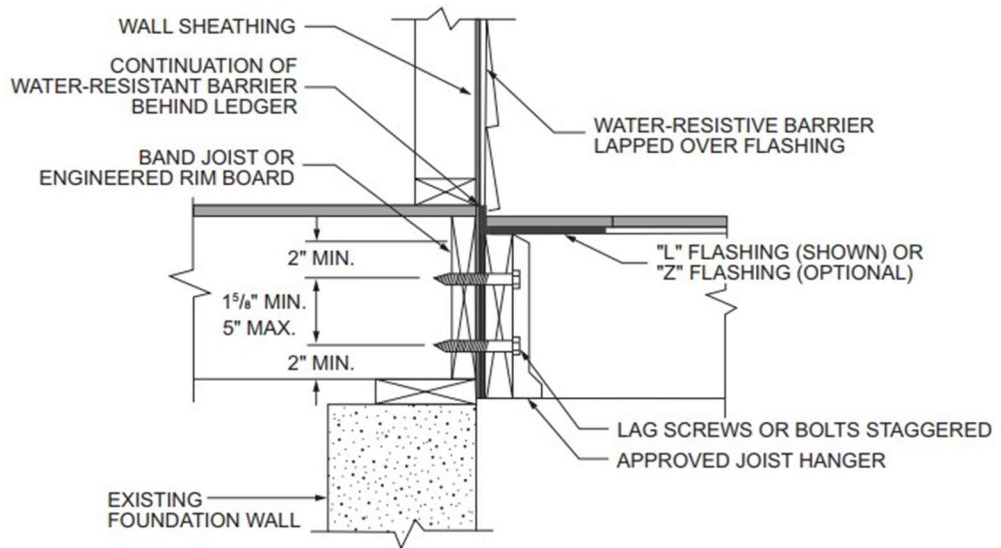

THIS DETAIL IS SHOWN AT A TYPICAL FOUNDATION WALL LOCATION. SIMILAR AT WOOD WALL.

For SI: 1 inch = 25.4 mm.

- Where ledgers are attached to wood-frame construction, flashing shall be installed above the ledger to prevent entry of water into the wall cavity, or behind the ledger. Flashing shall extend vertically not less than 2 inches above the ledger, extend to the ledger face and not less than 1/4" down the ledger face. (R507.9.1.5 of the 2025 RCNYS)
- Flashing shall be corrosion-resistant metal or nominal thickness not less than 0.019" or *approved* non-metallic material that is compatible with the substrate of the structure and the decking materials. Self-adhered membranes used as flashing and counterflashing shall comply with FGIA 711. (R507.2.4 of the 2025 RCNYS)
- Siding & ledger interface: Remove siding where required to properly flash and fasten the ledger. Do not penetrate the weather barrier without flashing.

Important: Improper ledger flashing or attachment is a leading cause of deck failures and house damage.

5) Joist & Beam Span Tables (how to size)

Deck Joists

- The code provides prescriptive span tables for typical wood species, joist sizes, and spacings. The prescriptive tables (Table R507.6 of the 2025 RCNYS) let you pick joist size and spacing based on the distance to the beam. Maximum joist cantilevers are also listed in this table.
- Joists are to be solid blocked over the beam to prevent lateral rotation. Where lateral restraint is provided by joist hangers or blocking between joists, their depth shall equal not less than 60 percent of the joist depth. (R507.6.2 of the 2025 RCNYS)

TABLE R507.6 – MAXIMUM DECK JOIST SPANS													
LOAD (psf)	JOIST SPECIES	JOIST SIZE	ALLOWABLE JOIST SPAN (feet-inches)			MAXIMUM CANTILEVER (feet-inches)							
			Joist spacing (inches)			Joist back span (feet)							
			12	16	24	4	6	8	10	12	14	16	18
40	Southern Pine	2 x 6	9 – 11	9 – 0	7 – 7	1 – 0	1 – 6	1 – 5	NP	NP	NP	NP	NP
		2 x 8	13 – 1	11 – 10	9 – 8	1 – 0	1 – 6	2 – 0	2 – 6	2 – 3	NP	NP	NP
		2 x 10	16 – 2	14 – 0	11 – 5	1 – 0	1 – 6	2 – 0	2 – 6	3 – 0	3 – 4	3 – 4	NP
		2 x 12	18 – 0	16 – 6	13 – 6	1 – 0	1 – 6	1 – 4	2 – 6	3 – 0	3 – 6	4 – 0	4 – 1

FIGURE R507.6—TYPICAL DECK JOIST SPANS

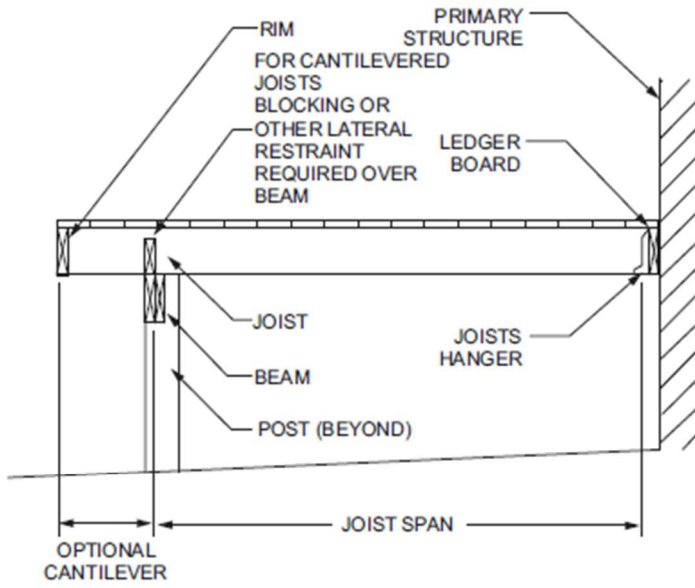

CANTILEVERED JOISTS WITH DROPPED BEAM

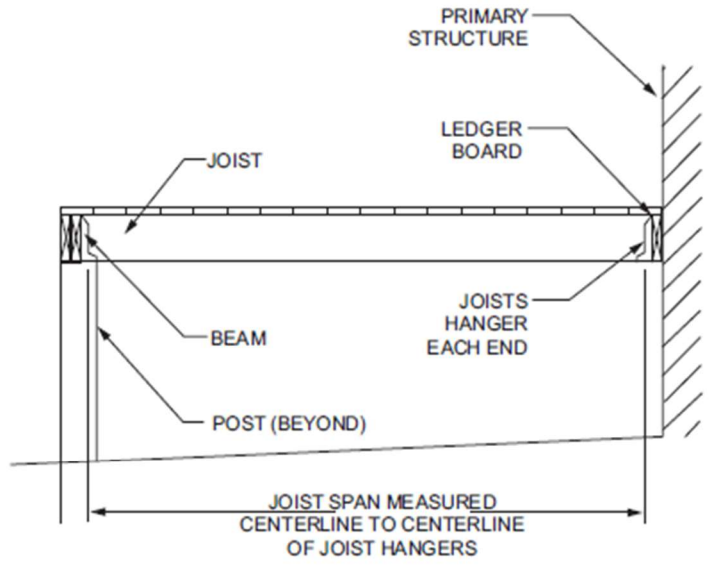

JOISTS WITH FLUSH BEAM

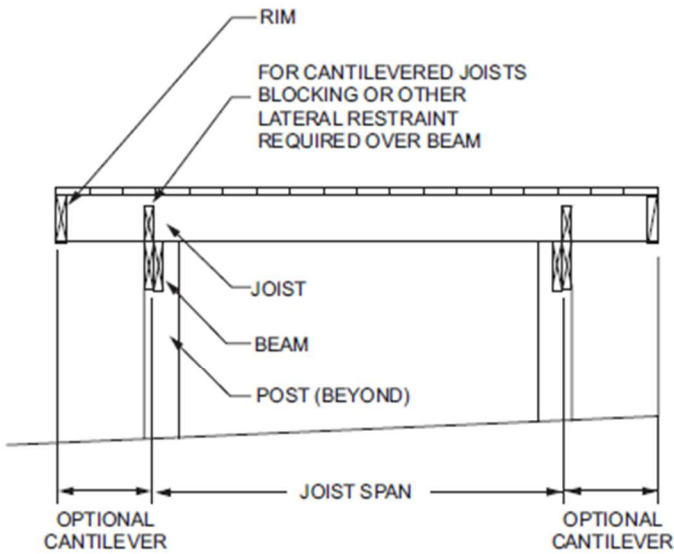

JOISTS ON FREE-STANDING DECK WITH DROPPED BEAM

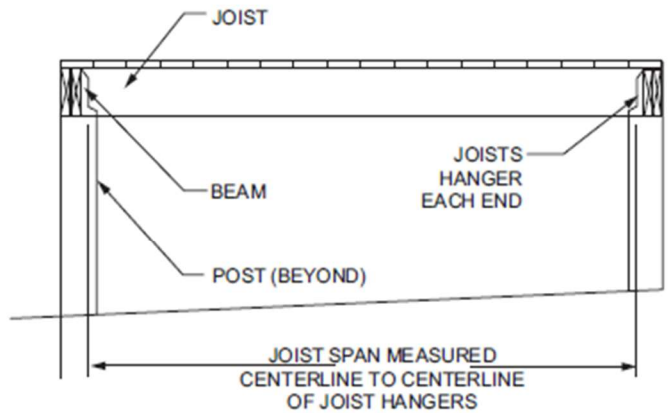

JOISTS ON FREE-STANDING DECK WITH FLUSH BEAM

Deck beams

- Maximum allowable spans for wood deck beams shall be in accordance with Tables R507.5(1) and based on the joist span length and cantilever length as shown in Figure R507.6. Beam plies shall be fastened together with two rows of 10d (3-inch × 0.128-inch) nails minimum at 16 inches on center along each edge (R507.5 of the 2025 RCNYS), or other *approved* fasteners.

TABLE R507.5(1) – MAXIMUM DECK BEAM SPAN – 4-psf LIVE LOAD b,e,f

JOIST SPAN		JOIST SPAN LENGTH AND JOIST CANTILEVER LENGTH (feet & feet)									
6	6 & 0	6 & 1.5									
8		8 & 0	8 & 1	8 & 2							
8			10 & 0	10 & 1	10 & 2.5						
12				12 & 0	12 & 1	12 & 2	12 & 3				
14					14 & 0	14 & 1	14 & 2	14 & 3.5			
16						16 & 0	16 & 1	16 & 2.5	16 & 4		
18							18 & 0	18 & 1.5	18 & 3	18 & 4.5	
BEAM SPECIES	BEAM SIZE	MAXIMUM DECK BEAM SPAN LENGTH (feet – inches)									
Southern Pine	1 – 2 x 6	4 – 10	4 – 7	4 – 3	4 – 0	3 – 7	3 – 5	3 – 3	3 – 0	2 – 10	2 – 8
	1 – 2 x 8	6 – 4	5 – 11	5 – 6	5 – 1	4 – 7	4 – 4	4 – 2	3 – 10	3 – 7	3 – 5
	1 – 2 x 10	7 – 6	7 – 0	6 – 6	6 – 0	5 – 5	5 – 2	4 – 11	4 – 7	4 – 3	4 – 0
	1 – 2 x 12	8 – 8	8 – 3	7 – 8	7 – 1	6 – 4	6 – 1	5 – 10	5 – 5	5 – 0	4 – 9
	2 – 2 x 6	7 – 4	6 – 11	6 – 5	5 – 11	5 – 4	5 – 1	4 – 10	4 – 6	4 – 3	4 – 0
	2 – 2 x 8	9 – 4	8 – 9	8 – 2	7 – 7	6 – 9	6 – 5	6 – 2	5 – 9	5 – 4	5 – 0
	2 – 2 x 10	11 – 0	10 – 4	9 – 8	9 – 0	8 – 0	7 – 8	7 – 4	6 – 9	6 – 4	6 – 0
	2 – 2 x 12	13 – 0	12 – 2	11 – 4	10 – 7	9 – 5	9 – 0	8 – 7	8 – 0	7 – 5	7 – 0
	3 – 2 x 6	9 – 0	8 – 6	7 – 11	7 – 5	6 – 8	6 – 4	6 – 1	5 – 8	5 – 3	4 – 11
	3 – 2 x 8	11 – 7	10 – 11	10 – 3	9 – 6	8 – 6	8 – 1	7 – 9	7 – 2	6 – 8	6 – 4
3 – 2 x 10	13 – 11	13 – 0	12 – 1	11 – 2	10 – 0	9 – 7	9 – 2	8 – 6	7 – 11	7 – 6	
3 – 2 x 12	16 – 3	15 – 3	14 – 3	13 – 3	11 – 10	11 – 3	10 – 9	10 – 0	9 – 4	8 – 10	

b. Beams supporting a single span of joists with or without cantilever.

e. Beam depth shall be equal to or greater than the depth of intersecting joist for a flush beam connection.

f. Beam cantilevers are limited to the adjacent beam's span divided by 4.

- Beams and individual beam plies of built-up beams shall be continuous between bearing locations and continuous across bearing locations supporting beam cantilevers. (can only break a beam ply over a post)
- Beams shall be permitted to cantilever beyond bearing locations up to one-fourth of the adjacent beam span (between posts)
- The ends of beams shall have not less than 1-1/2 inches of bearing length on wood or metal and not less than 3 inches of bearing length on concrete or masonry for the entire width of the beam. (R507.5.1 of the 2025 RCNYS)
- Deck beams shall be connected to supporting members to prevent lateral displacement. Deck beam connections to wood posts shall be in accordance with Figures R507.5.2(1) and R507.5.2(2). Manufactured post-to-beam connectors shall be sized for the post and beam sizes. Bolts shall have washers under the head and nut. (R507.5.2 of the 2025 RCNYS)
- Beams must be direct bearing on posts, “sandwiching” of beams onto posts is not allowed

Example: A deck that is 12' from ledger to edge of the deck with a 2' joist cantilever over the beam- in the chart above, find the column "Joist Span", go down to 12' and the over to 12 & 2 (12' joist span w/ 2' cantilever). Then follow that column down to find the beam size and post spacing for each lumber size.

FIGURE R507.5.2(1)
DECK BEAM TO DECK POST

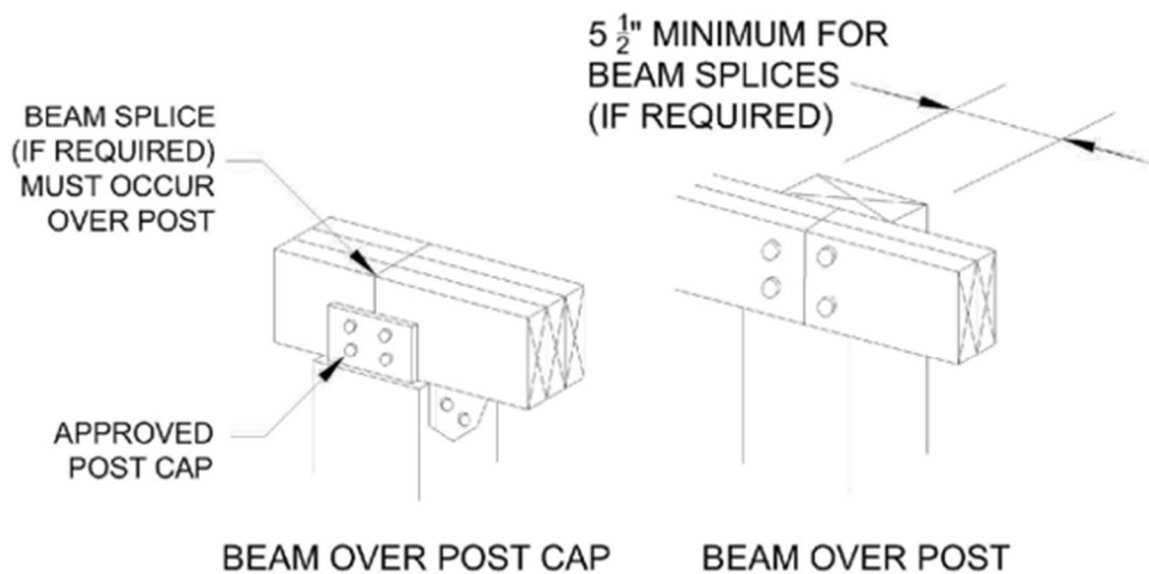
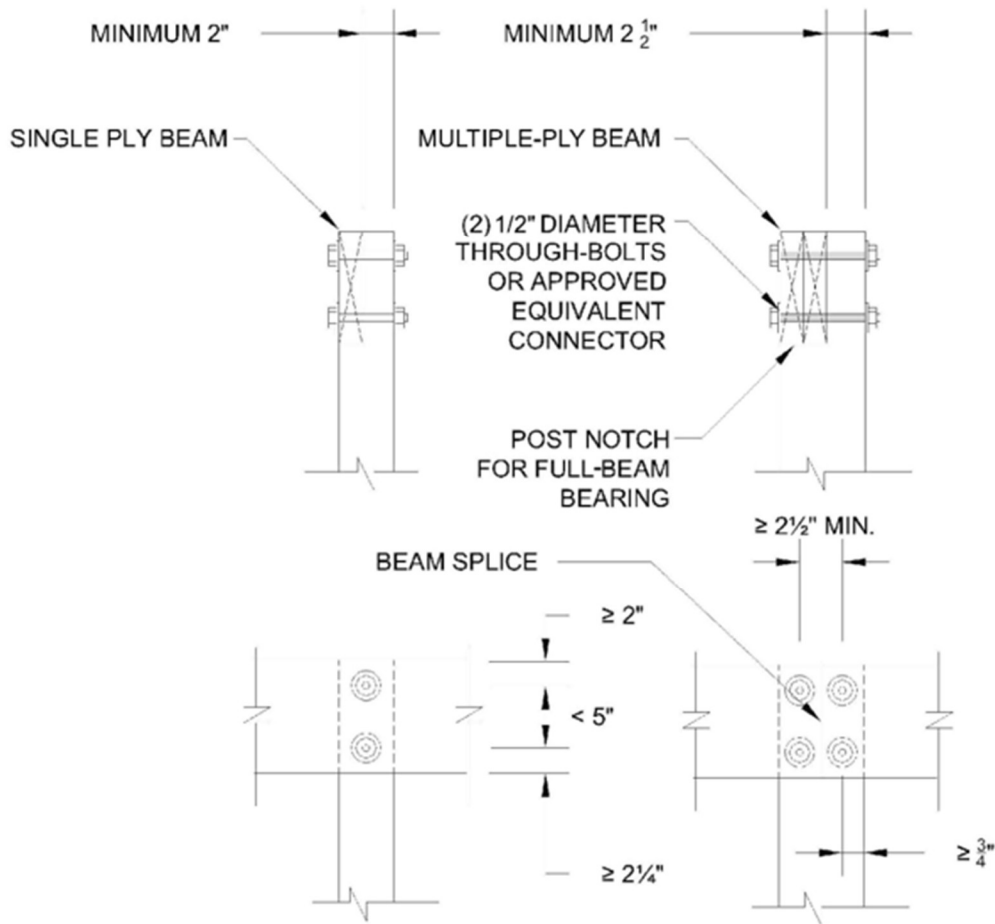

FIGURE R507.5.2(2)
NOTCHED POST TO BEAM CONNECTION



6) Lateral Connection

- Lateral loads shall be transferred to the ground or to a structure capable of transmitting them to the ground.
 - Where the lateral load connection is provided in accordance with Figure R507.9.2(1), hold-down tension devices shall be installed in not less than two locations per deck, within 24 inches of each end of the deck. Each device shall have an allowable stress design capacity of not less than 1,500 pounds.
 - Where the lateral load connections are provided in accordance with Figure R507.9.2(2), the hold-down tension devices shall be installed in not less than four locations per deck, and each device shall have an allowable stress design capacity of not less than 750 pounds.

FIGURE R507.9.2(1)—DECK ATTACHMENT FOR LATERAL LOADS

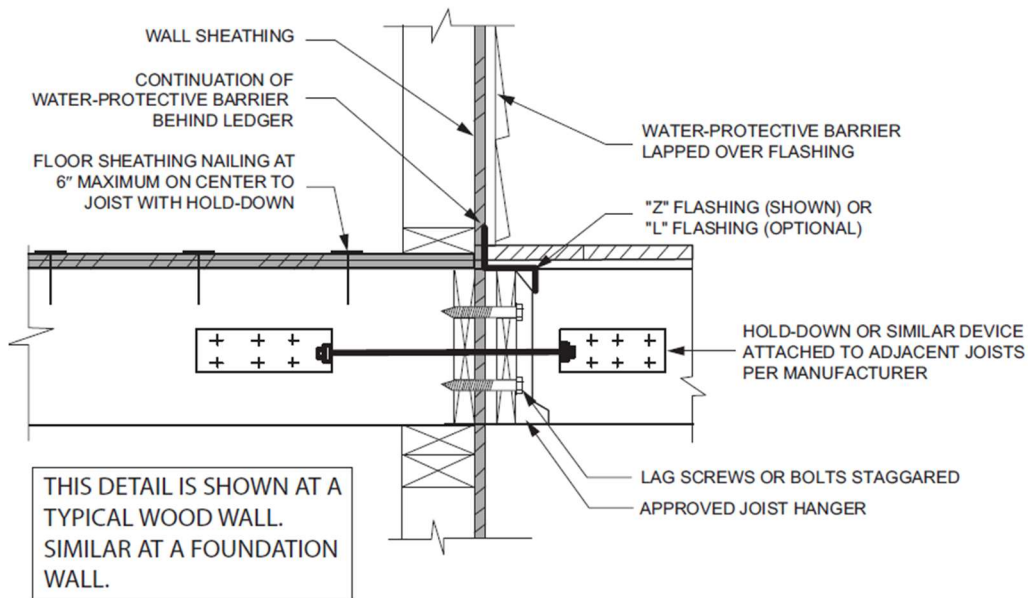
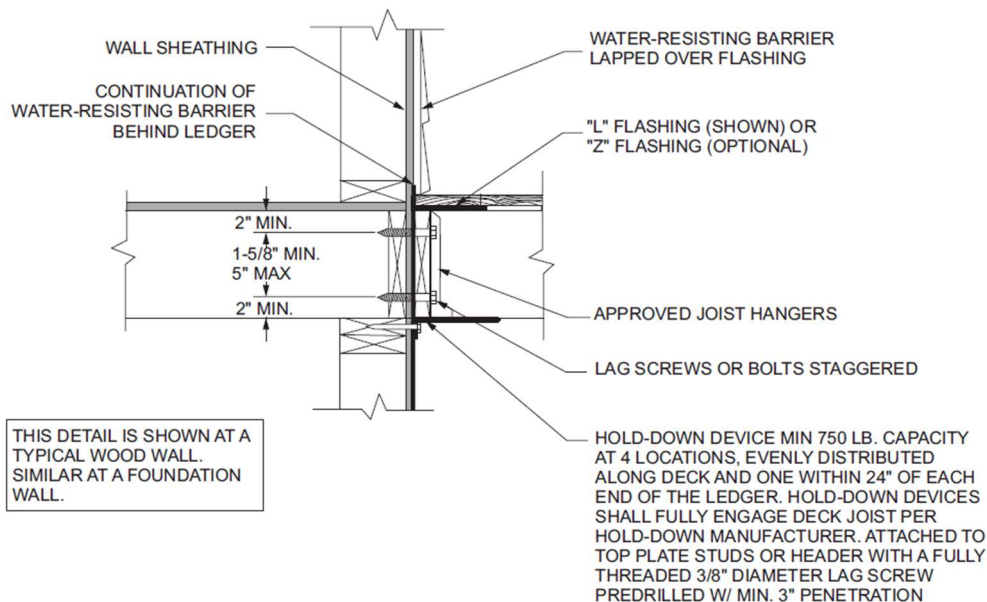

FIGURE R507.9.2(2)—DECK ATTACHMENT FOR LATERAL LOADS



7) Guards (railings), Stairs & Handrails

- Guards are required when the deck surface is more than **30 inches** above grade, within **36 inches** from the edge of the deck. Residential guard height is **36 inches** measured from the deck surface to the top of the guard. (R321.1.1 of the 2025 RCNYS)
 - Baluster spacing: Openings in the guard should not allow passage of a 4-inch sphere. (R321.1.3 of the 2025 RCNYS)
 - **Exceptions:**
 - 1. The triangular openings at the open side of *stair*, formed by the *riser*, tread, and bottom rail of a *guard*, shall not allow passage of a sphere 6 inches in diameter.
 - 2. *Guards* on the open side of *stairs* shall not have openings that allow passage of a sphere 4-3/8 inches in diameter.
 - Guard/rail loads: Guards and handrails must resist a minimum of 200lbs of concentrated and uniform loads (Table R301.5 of the 2025 RCNYS).
 - Stair width minimum is **36 inches**, clear width at all points above the permitted handrail height. The clear width of stairways at and below the height of the handrail, including treads and landings, shall be not less than **31-1/2 inches** where a handrail is installed on one side. Where a handrail is installed on both sides, the clear width shall not be less than **27 inches**. (R318.7.1 of the 2025 RCNYS)
 - Treads & risers: Maximum riser height is 8-1/4 inches, and minimum tread depth is 9 inches. The greatest tread depth within any *flight* of stairs shall not exceed the smallest by more than 3/8 inch. (R318.7.5.1 & R318.7.5.2 of the 2025 RCNYS)
 - Exterior *stairways* shall be provided with an artificial light source located at the top landing of the *stairway*. (R325.7 of the 2025 RCNYS)
 - A *flight* of stairs shall not have a vertical rise greater than 12 feet 7 inches between floor levels or landings. (R318.7.3 of the 2025 RCNYS)
 - Handrails are required on not less than one side of each flight of stairs with four or more risers. (R318.7.8 of the 2025 RCNYS)
 - Handrail height is **34–38 inches** measured from the nosing; *continuous graspable* handrails are required. A vertical 2"x4" or flat 5/4" x 6" decking board is not graspable. (R320.2 of the 20205 RCNYS)
-

8) Typical construction sequence

1. Plan, prepare drawings, get permit.
 2. Locate utilities and mark footings.
 3. Dig footing holes to appropriate diameter & depth, install footings & set posts.
 4. Install post bases (if not burying posts), beams, and ledger (if deck is attached to house).
 5. Install joists and joist hangers/mechanical connectors.
 6. Install blocking and ledger flashing.
 7. Install decking boards and fasteners.
 8. Build stairs, guards, and handrails.
 9. Final inspections and finish (stain/paint as desired).
-

9) Inspection checklist

- Footings depth & location (before pouring concrete).
 - Framing
 - Footing to post (if posts are not buried), and post to beam connections.
 - Beam size & beam ply fasteners
 - Joist size, joist to beam & joist to ledger attachments
 - Ledger attachment and flashing (if attached to house)
 - Joist hanger installation and blocking
 - Lateral load connectors/deck tension ties (if attached to house)
 - Final Inspection
 - Guardrail height, strength, and baluster spacing
 - Stairs: riser/tread uniformity and handrail continuity
-

10) Deck Plan Example

Example Deck Top View

- Add beams as needed to fit your design.
- Fill in dimensions to fit your design.
- Indicate the distance from the ground to the top of the deck.
- **Decks can be free standing and not attached to the house, this would require additional beams.**

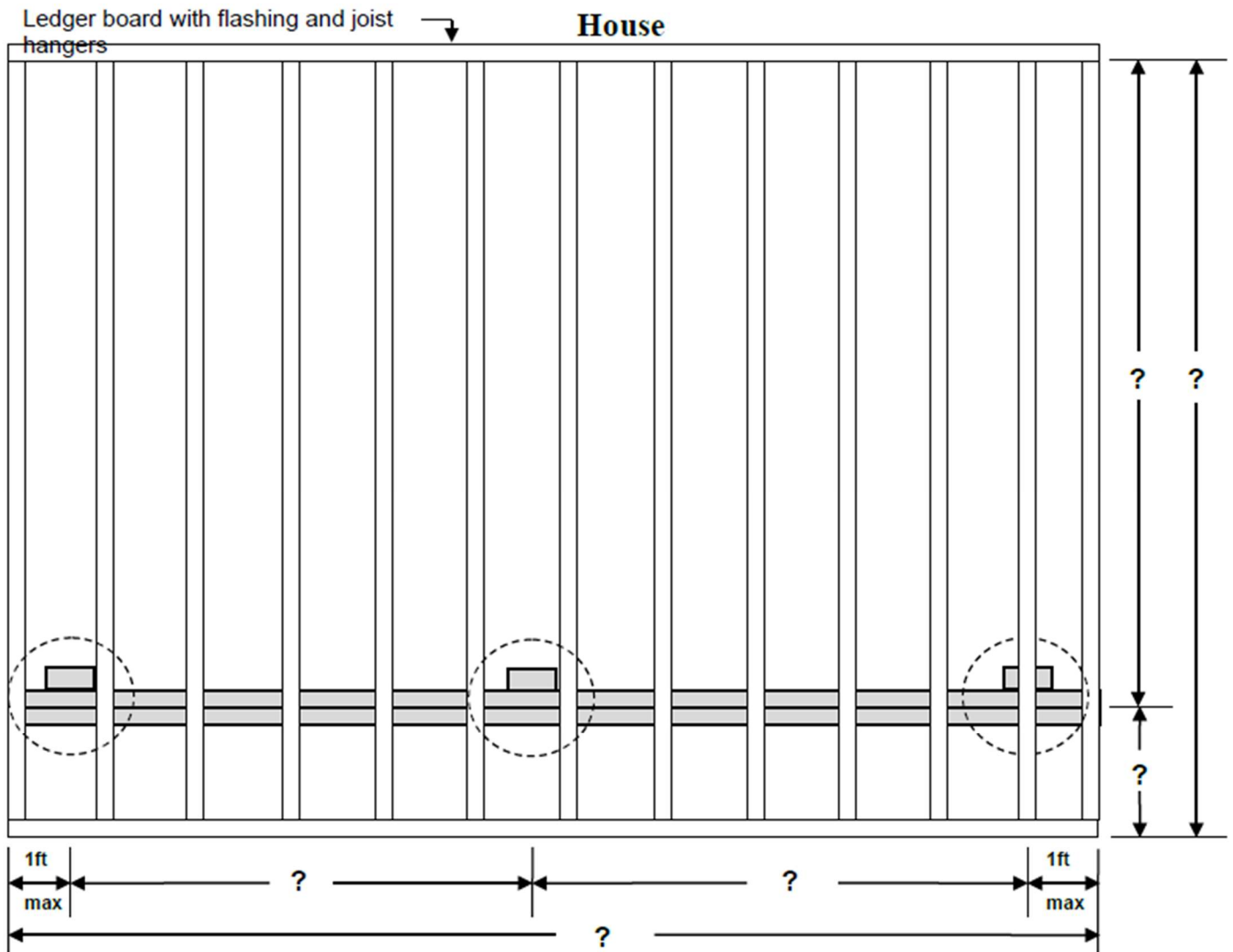

Example Deck Cross Section

